

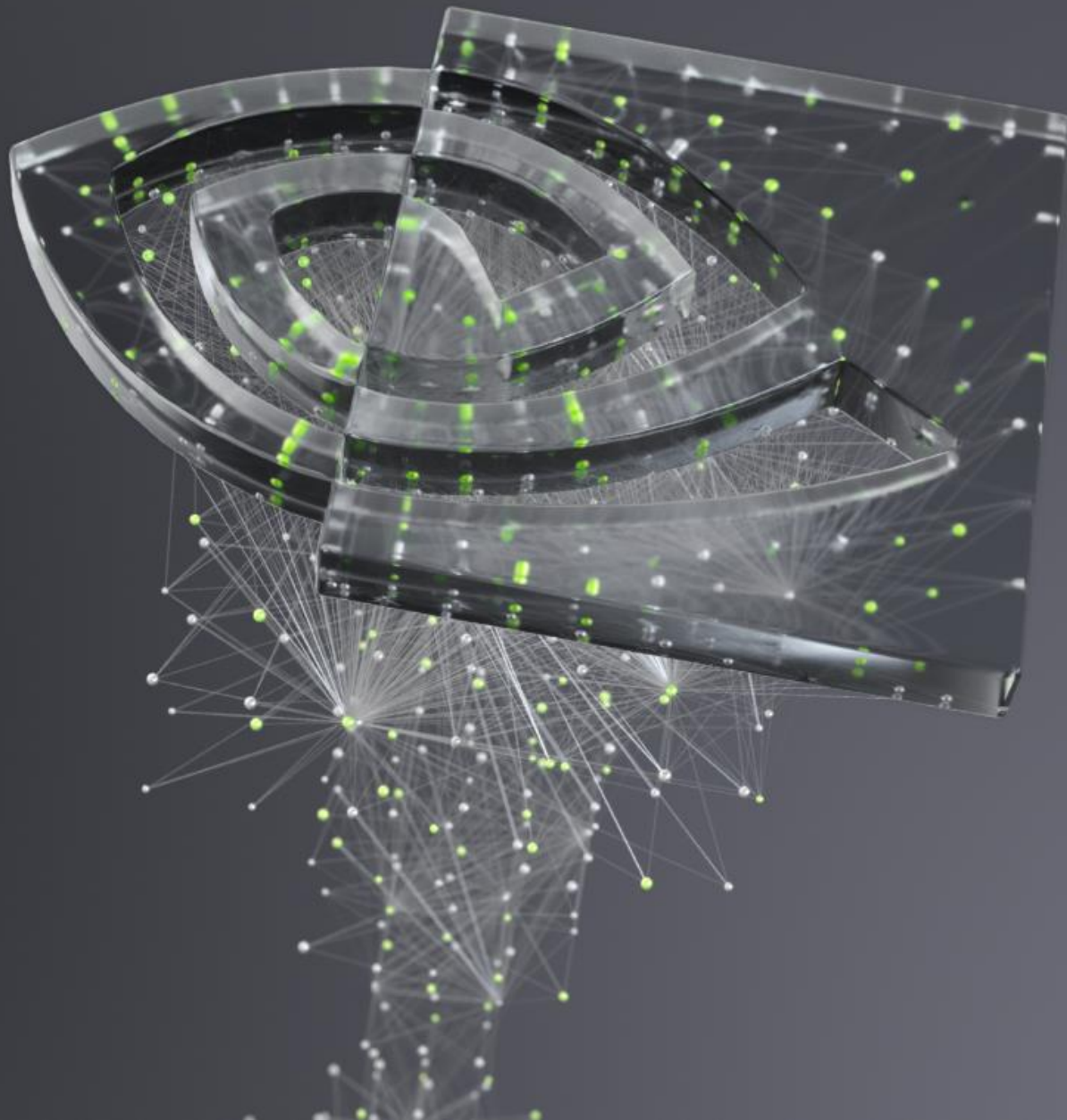

DEEP
LEARNING
INSTITUTE

FUNDAMENTALS OF DEEP LEARNING

Part 6: Advanced Architectures



AGENDA

Part 1: An Introduction to Deep Learning

Part 2: How a Neural Network Trains

Part 3: Convolutional Neural Networks

Part 4: Data Augmentation and Deployment

Part 5: Pre-trained Models

Part 6: Advanced Architectures

AGENDA – PART 6

- Moving Forward
- Natural Language Processing
- Recurrent Neural Networks
- Other Architectures
- Closing Thoughts



MOVING FORWARD

FIELDS OF AI



Computer Vision

- Optometry



Natural Language Processing

- Linguistics

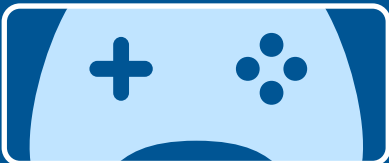

Reinforcement Learning

- Game Theory
- Psychology



Anomaly Detection

- Security
- Medicine

FIELDS OF AI



Computer Vision

- Optometry



Natural Language Processing

- Linguistics

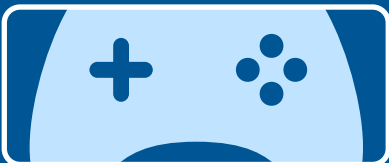

Reinforcement Learning

- Game Theory
- Psychology



Anomaly Detection

- Security
- Medicine

FIELDS OF AI



Computer Vision

- Optometry

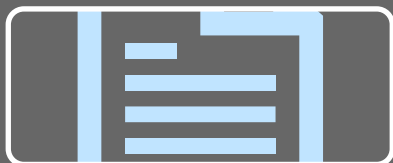

Natural Language Processing

- Linguistics

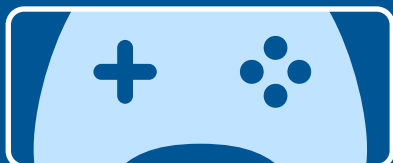

Reinforcement Learning

- Game Theory
- Psychology



Anomaly Detection

- Security
- Medicine



NATURAL LANGUAGE PROCESSING

FROM WORDS TO NUMBERS

“A dog barked at a cat.”

[1, 10, 7, 4, 1, 8]

DICTIONARY

- | | |
|-----------|----------|
| 1. A | 8. CAT |
| 2. AN | 9. CATS |
| 3. AND | 10. DOG |
| 4. AT | 11. DOGS |
| 5. ATE | 12. EAT |
| 6. BARK | |
| 7. BARKED | |

FROM WORDS TO NUMBERS

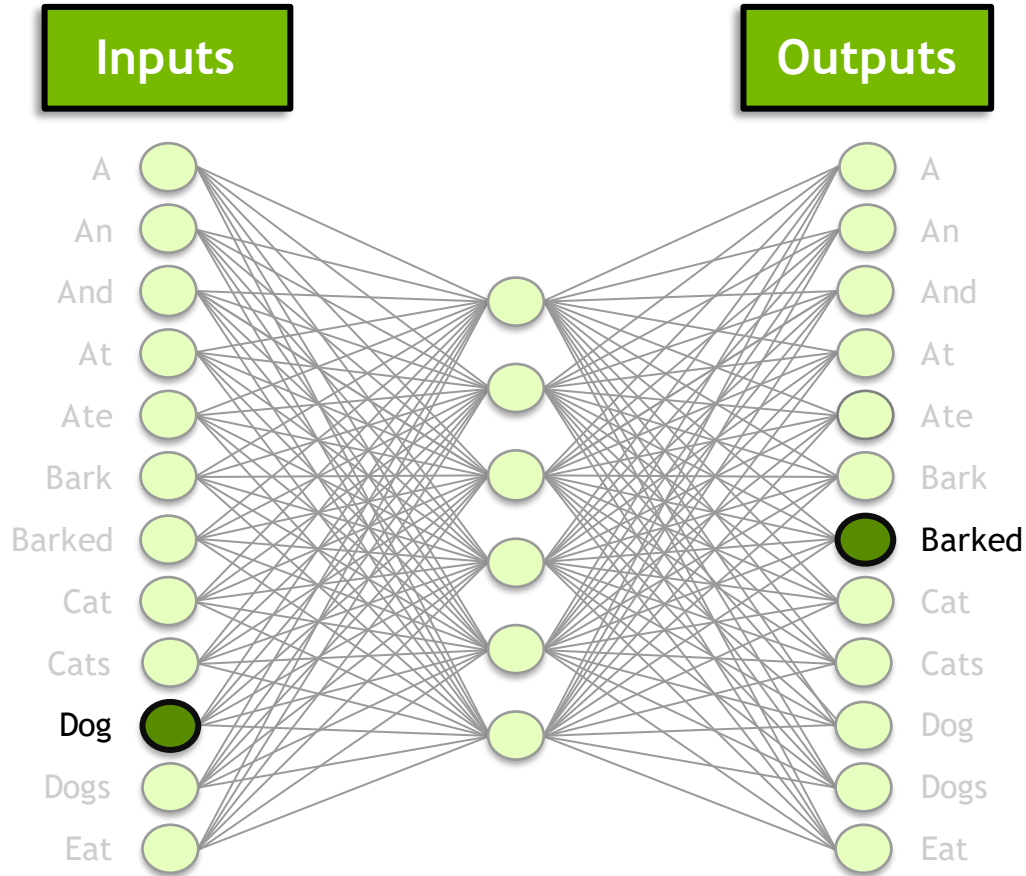

DICTIONARY

1. A
2. AN
3. AND
4. AT
5. ATE
6. BARK
7. BARKED
8. CAT
9. CATS
10. DOG
11. DOGS
12. EAT

FROM WORDS TO NUMBERS

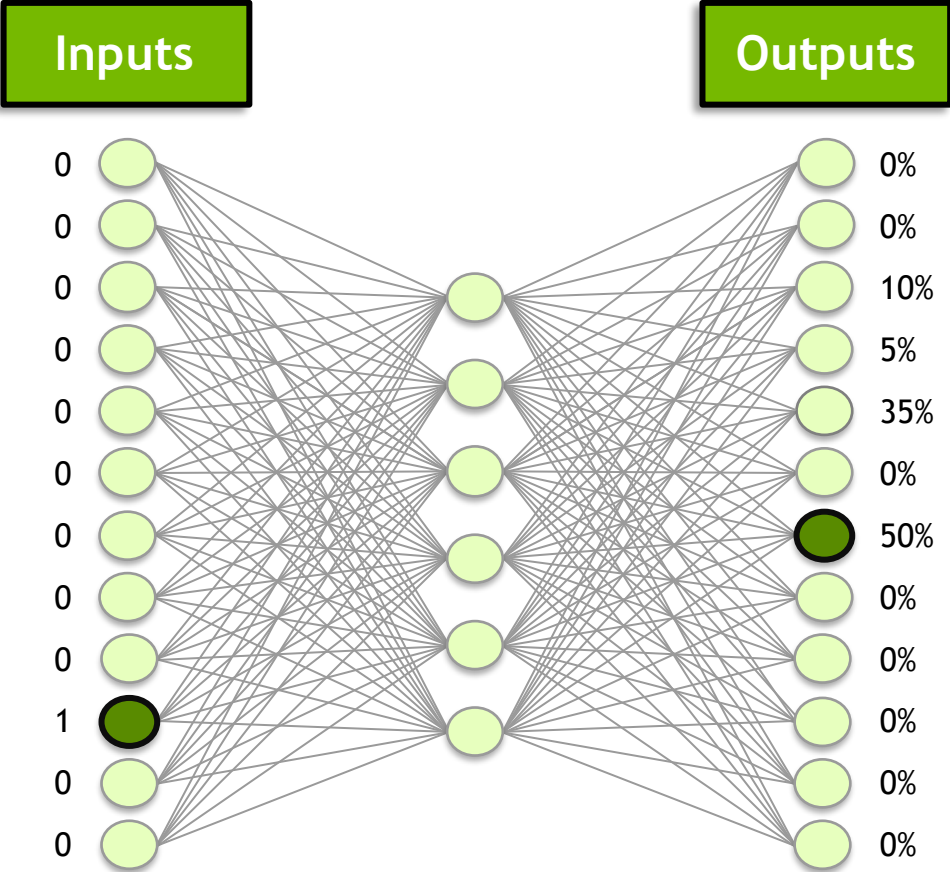

DICTIONARY

1. A	8. CAT
2. AN	9. CATS
3. AND	10. DOG
4. AT	11. DOGS
5. ATE	12. EAT
6. BARK	
7. BARKED	

FROM WORDS TO NUMBERS

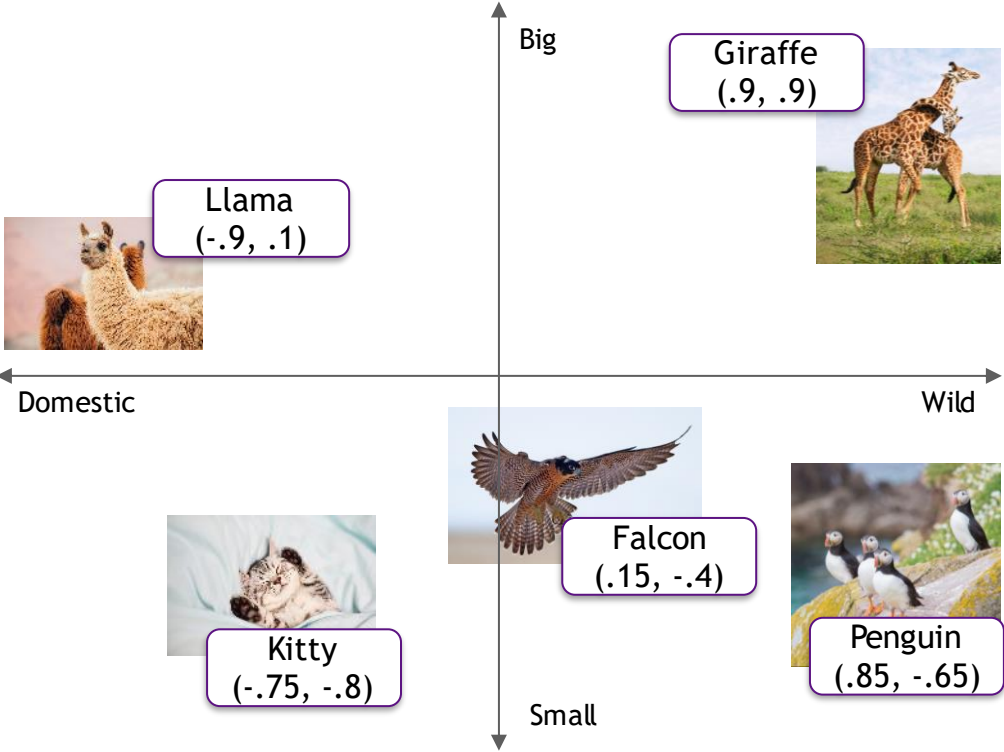

BIGGER DICTIONARY

1. A	31. ATE	61. CATS
2. AN	32. BARK	62. DOG
3. AND	33. BARKED	63. DOGS
4. AT	34. CAT	64. EAT
5. ATE	35. CATS	65. EATEN
6. BARK	36. DOG	66. A
7. BARKED	37. DOGS	67. AN
8. CAT	38. EAT	68. AND
9. CATS	39. EATEN	69. AT
10. DOG	40. A	70. ATE
11. DOGS	41. AN	71. BARK
12. EAT	42. AND	72. BARKED
13. EATEN	43. AT	73. CAT
14. A	44. ATE	74. CATS
15. AN	45. BARK	75. DOG
16. AND	46. BARKED	76. DOGS
17. AT	47. CAT	77. EAT
18. ATE	48. CATS	78. EATEN
19. BARK	49. DOG	79. ...
20. BARKED	50. DOGS	80. ...
21. CAT	51. EAT	81. ...
22. CATS	52. EATEN	82. ...
23. DOG	53. A	
24. DOGS	54. AN	
25. EAT	55. AND	
26. EATEN	56. AT	
27. A	57. ATE	
28. AN	58. BARK	
29. AND	59. BARKED	
30. AT	60. CAT	

FROM WORDS TO NUMBERS

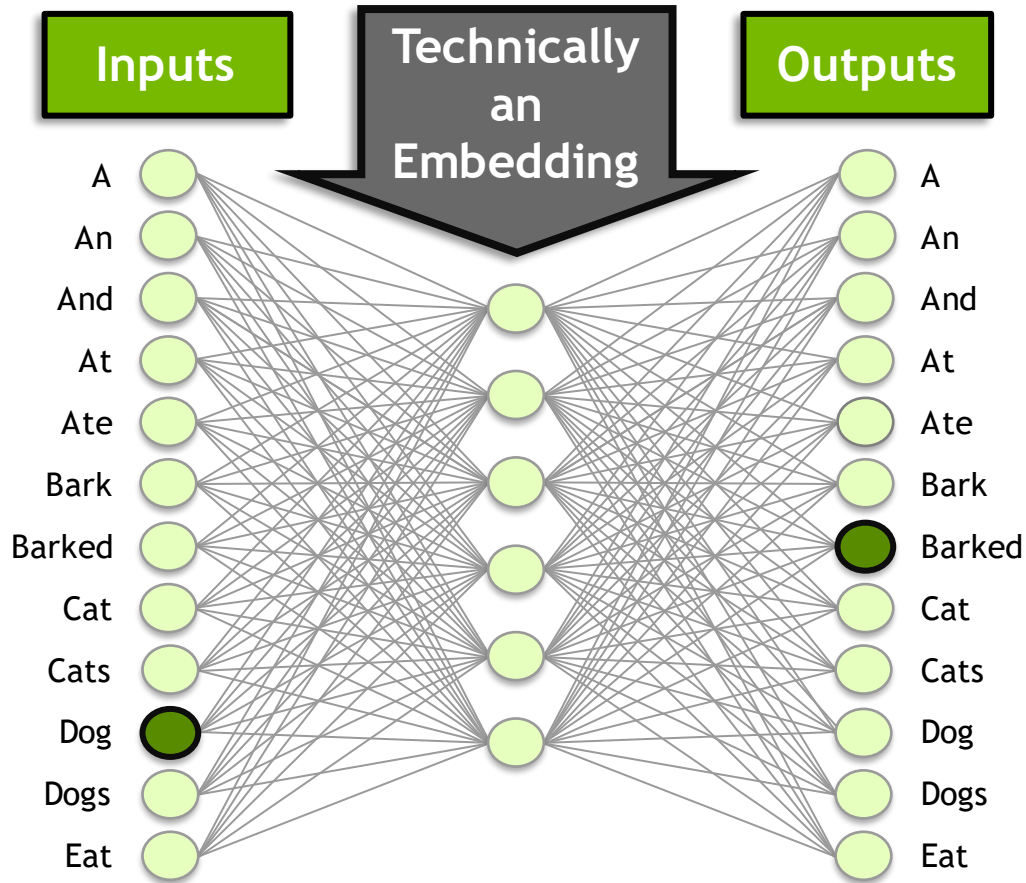

DICTIONARY

1. A	8. CAT
2. AN	9. CATS
3. AND	10. DOG
4. AT	11. DOGS
5. ATE	12. EAT
6. BARK	
7. BARKED	



RECURRENT NEURAL NETWORKS

RECURRENT NEURAL NETWORKS

“Cats say ____.”

“Dogs say ____.”

DICTIONARY

1. CATS
2. DOGS
3. MEOW
4. SAY
5. WOOF

RECURRENT NEURAL NETWORKS

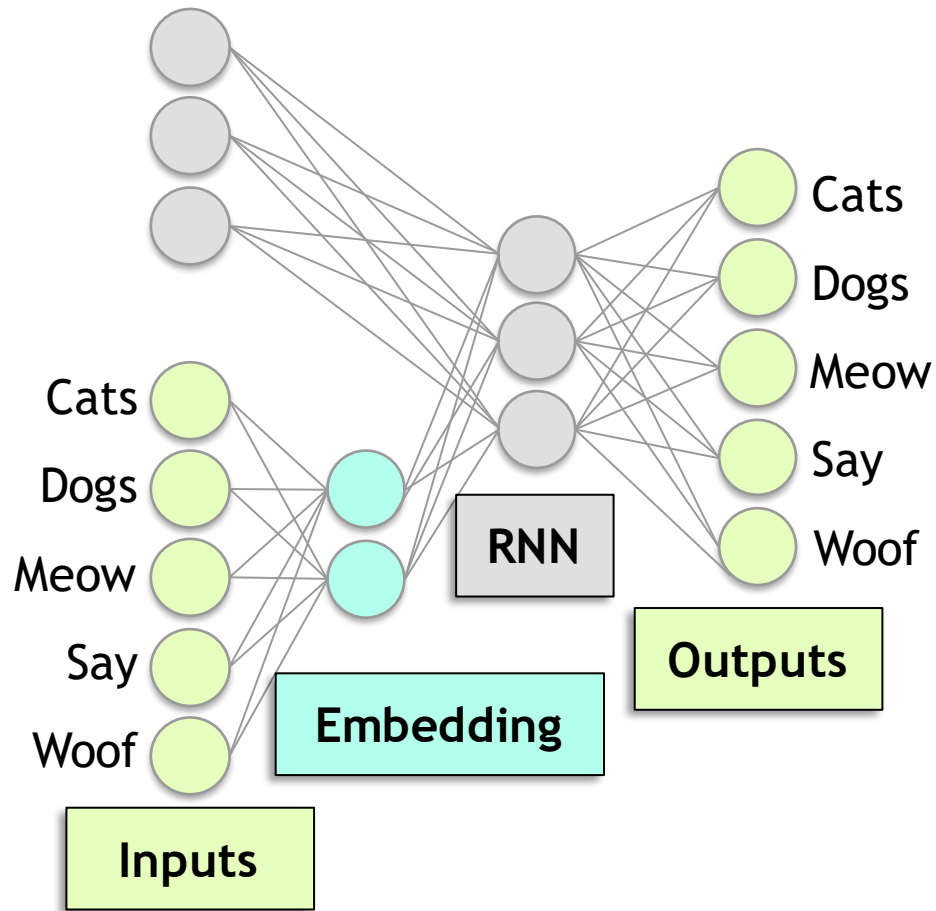

“Cats say ____.”

“Dogs say ____.”

DICTIONARY

1. CATS
2. DOGS
3. MEOW
4. SAY
5. WOOF

RECURRENT NEURAL NETWORKS

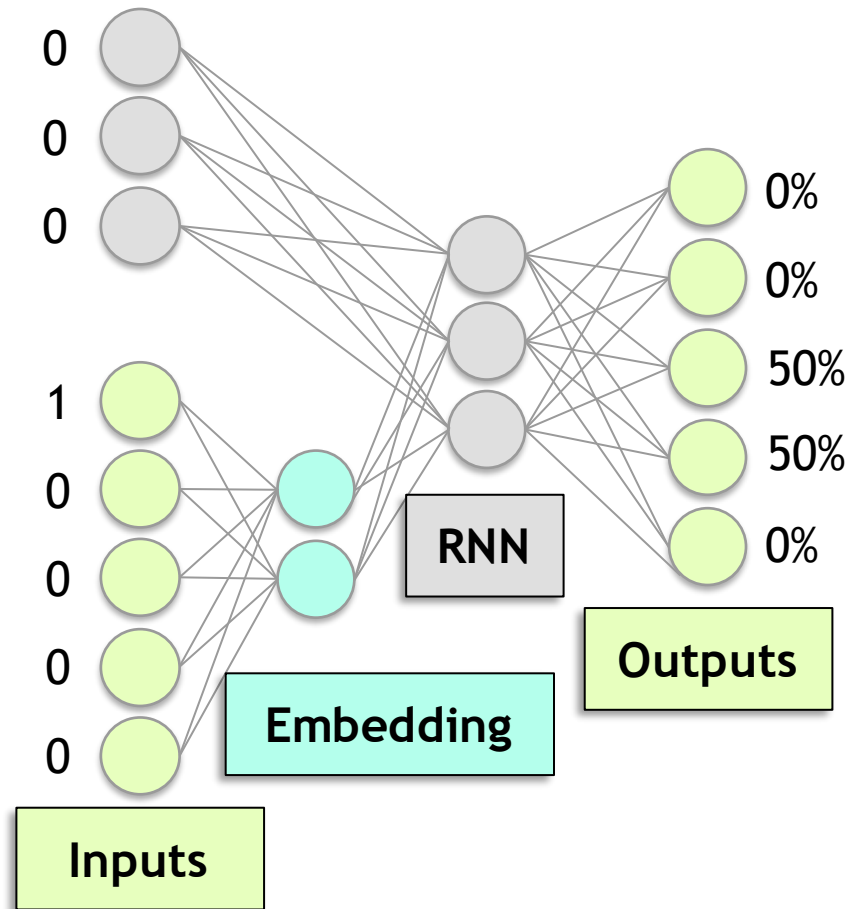

“Cats say ____.”

“Dogs say ____.”

DICTIONARY

1. CATS
2. DOGS
3. MEOW
4. SAY
5. WOOF

RECURRENT NEURAL NETWORKS

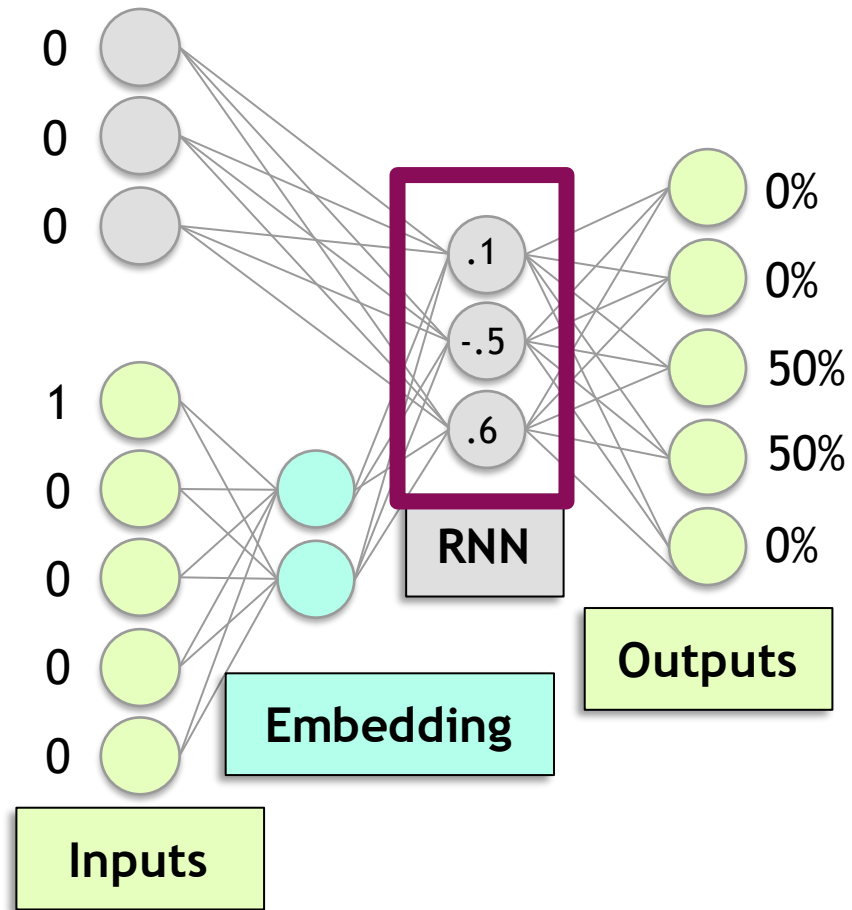

“Cats say ____.”

“Dogs say ____.”

DICTIONARY

1. CATS
2. DOGS
3. MEOW
4. SAY
5. WOOF

RECURRENT NEURAL NETWORKS

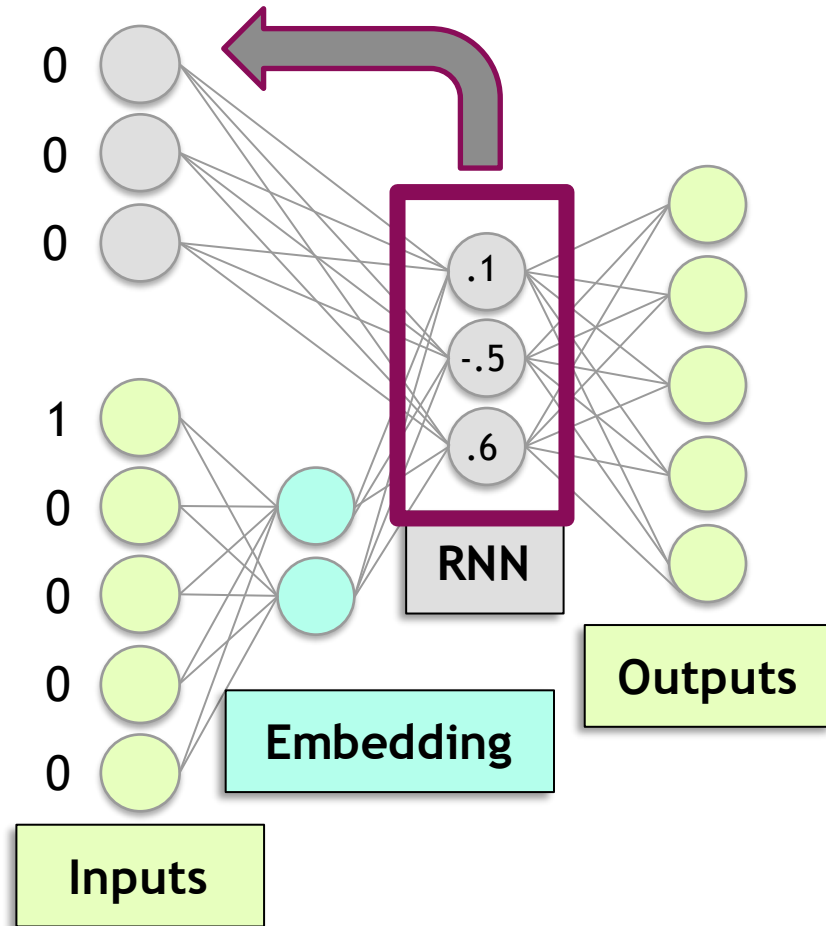

“Cats say ____.”

“Dogs say ____.”

DICTIONARY

1. CATS
2. DOGS
3. MEOW
4. SAY
5. WOOF

RECURRENT NEURAL NETWORKS

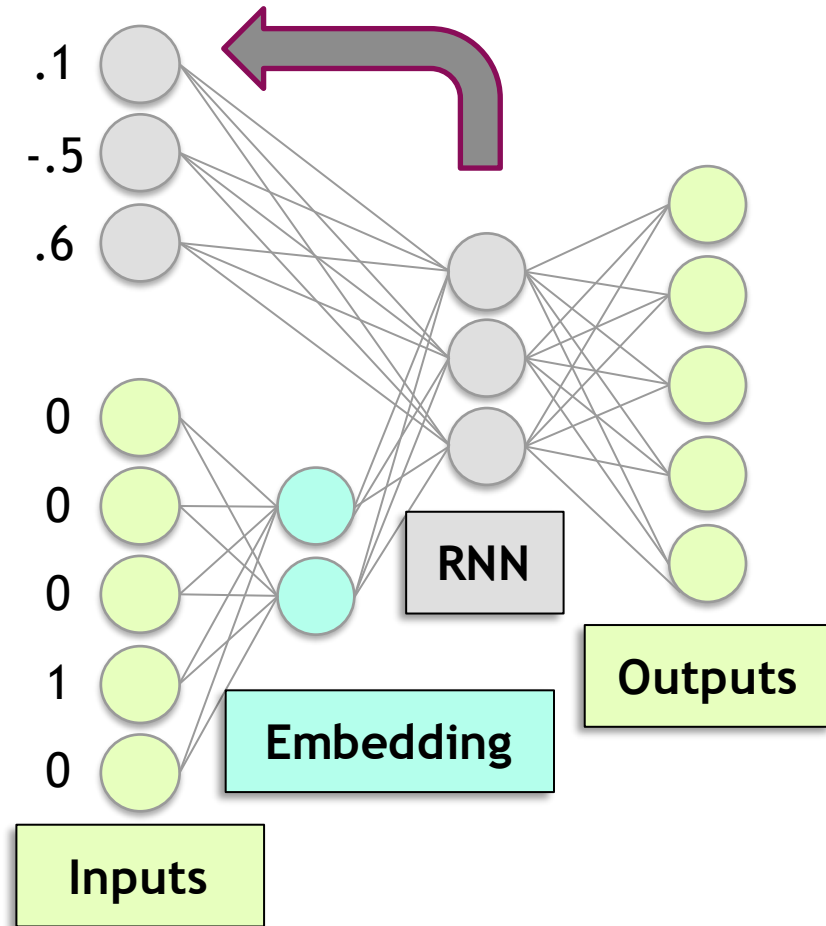

“Cats say ____.”

“Dogs say ____.”

DICTIONARY

1. CATS
2. DOGS
3. MEOW
4. SAY
5. WOOF

RECURRENT NEURAL NETWORKS

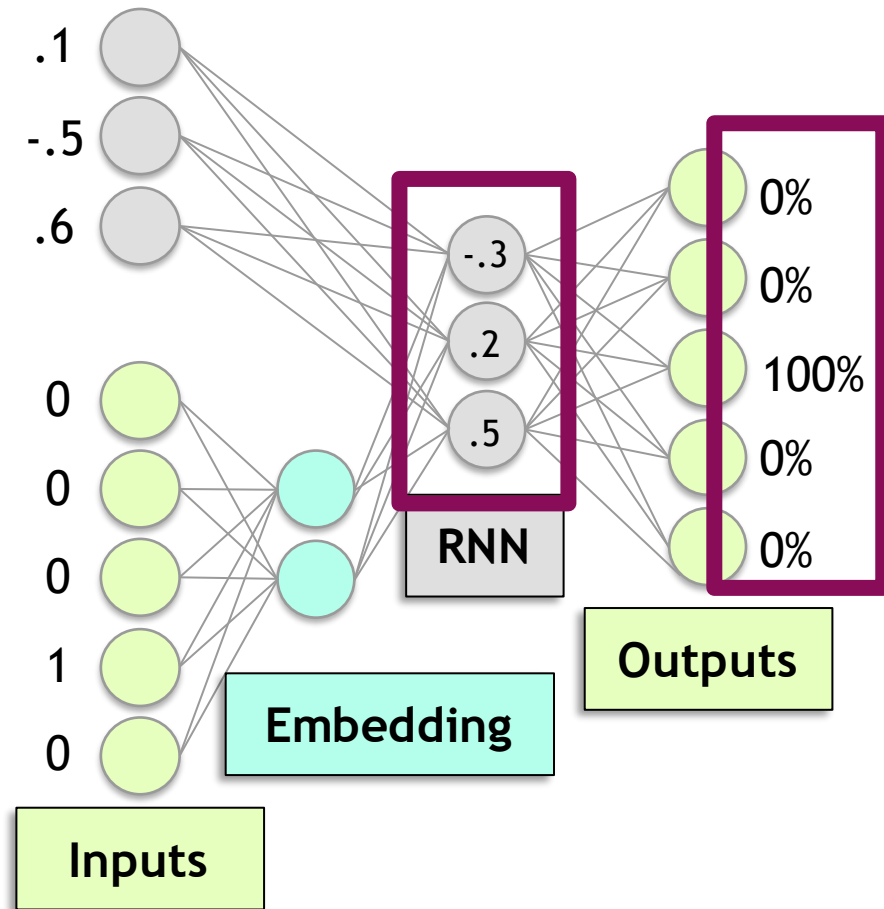

“Cats say ____.”

“Dogs say ____.”

DICTIONARY

1. CATS
2. DOGS
3. MEOW
4. SAY
5. WOOF

RECURRENT NEURAL NETWORKS

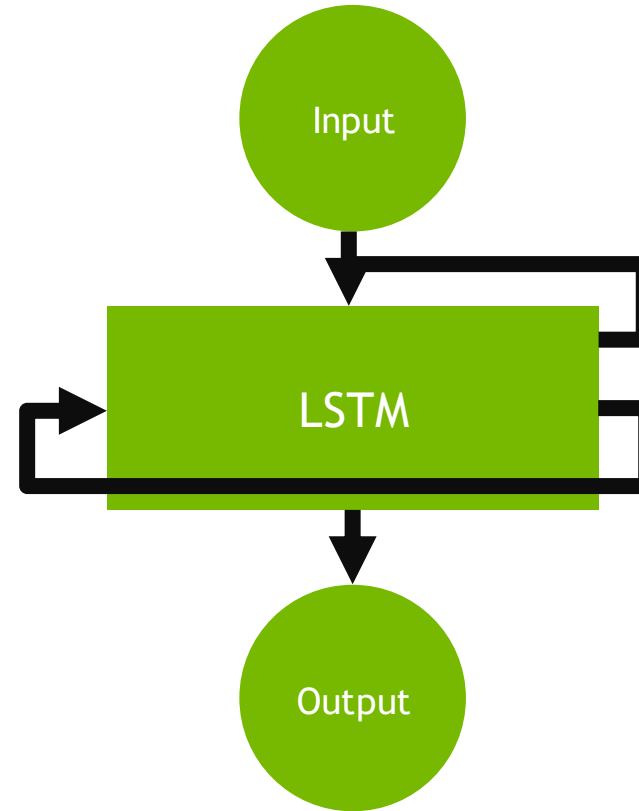
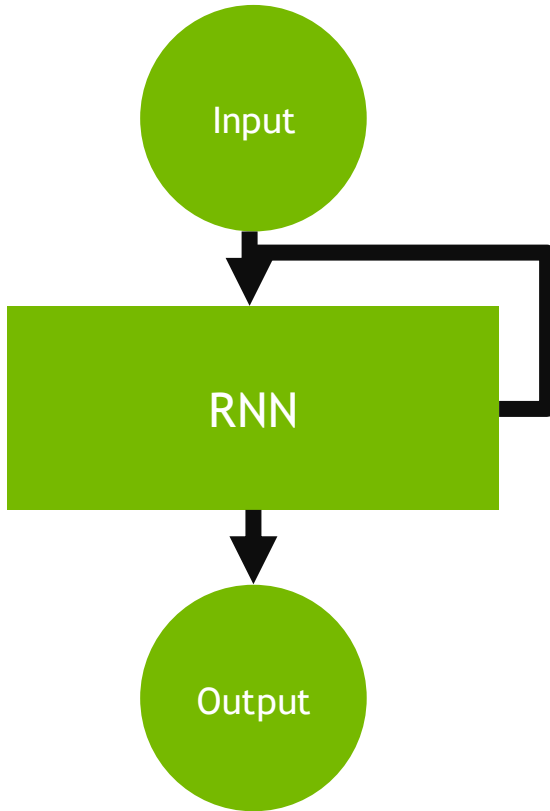



OTHER ARCHITECTURES

AUTOENCODERS

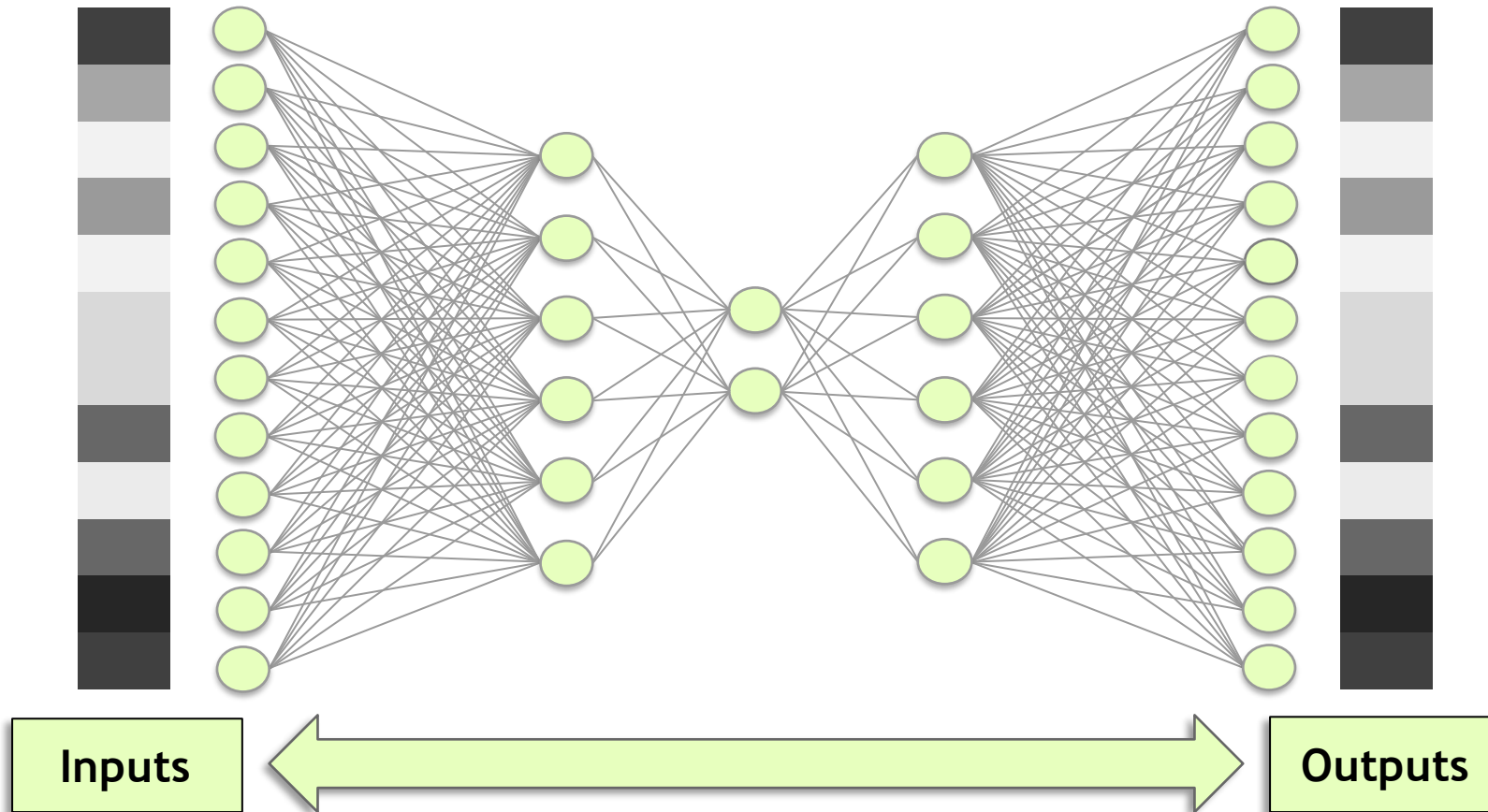

AUTOENCODERS

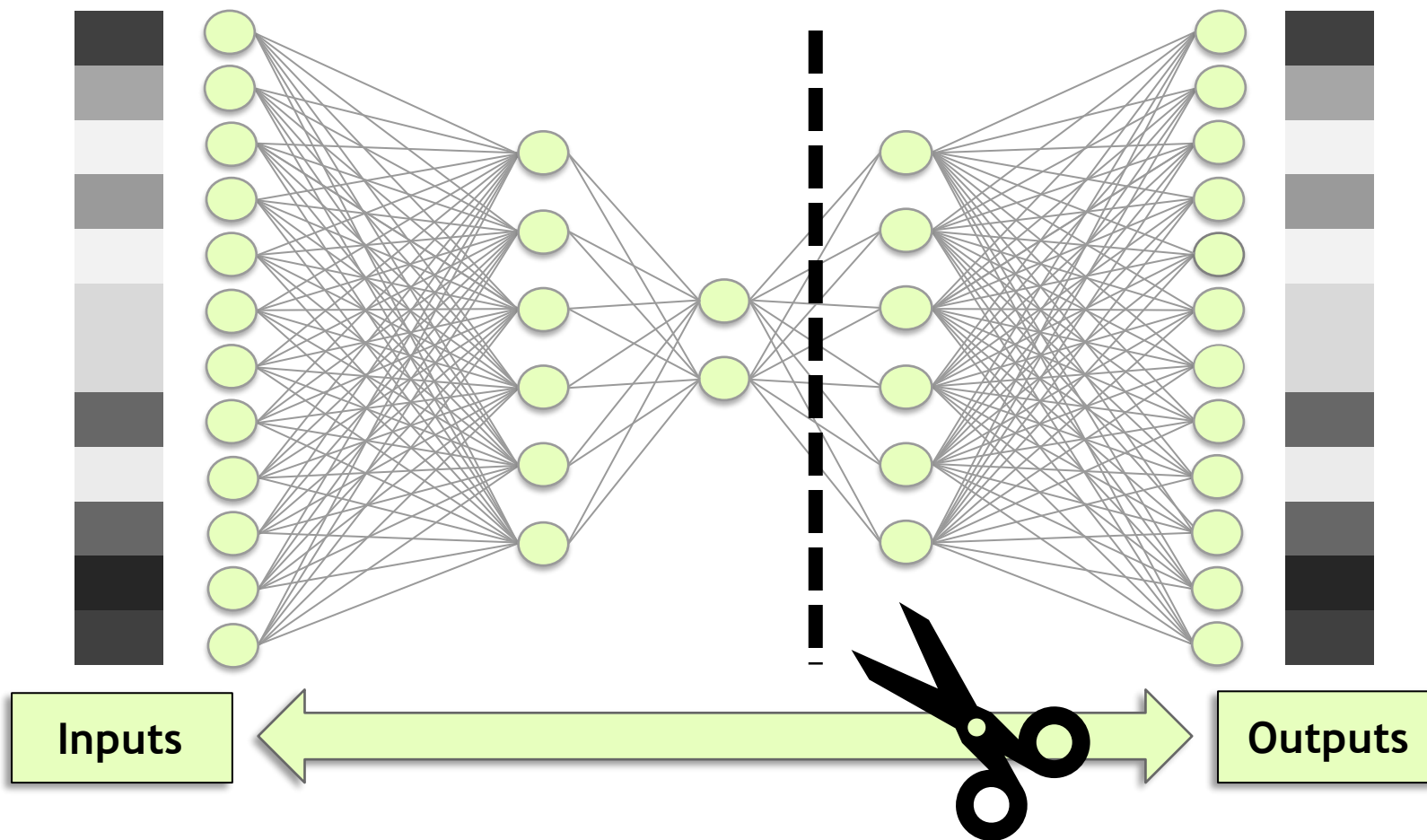

AUTOENCODERS

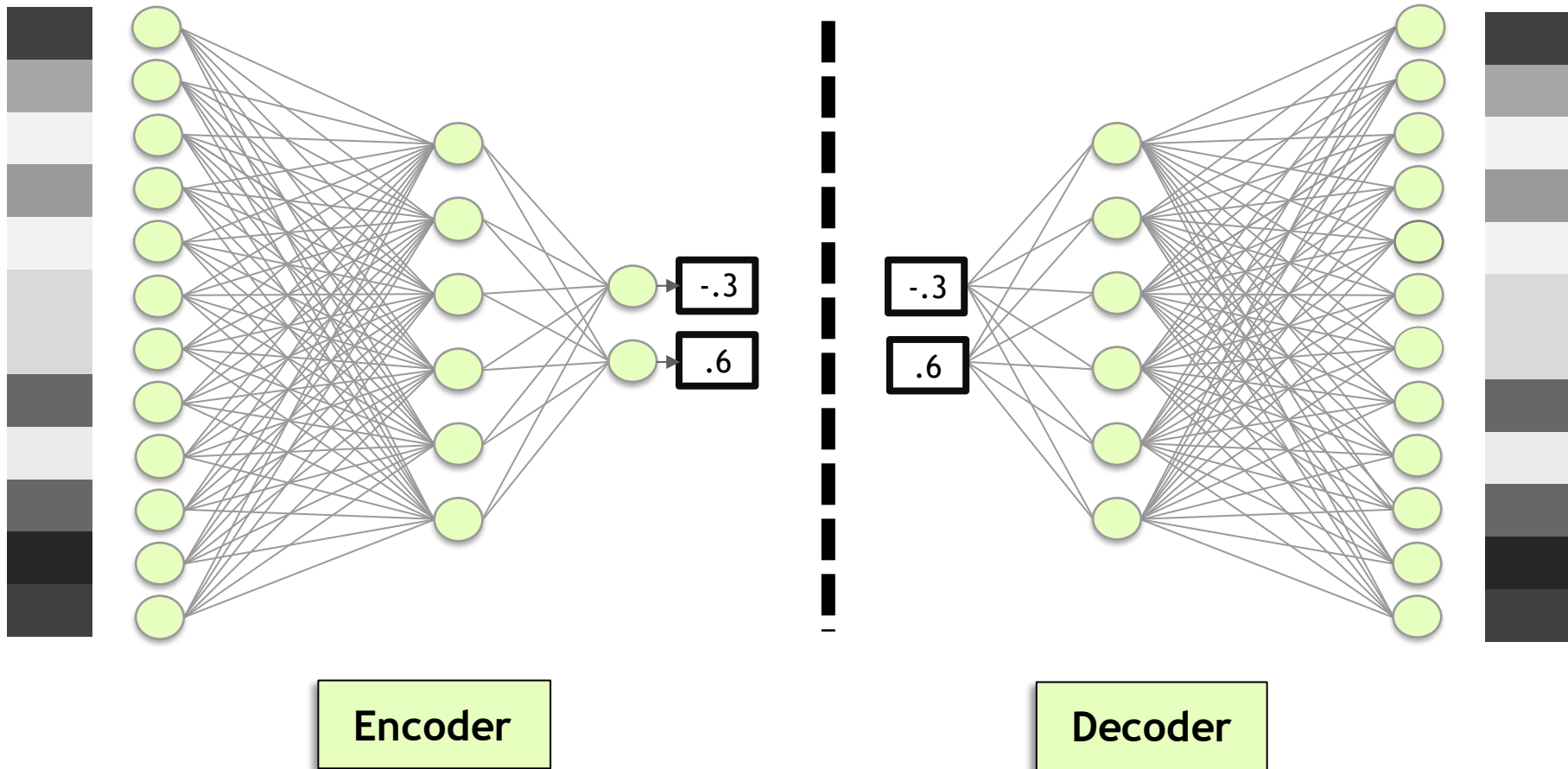

GENERATIVE ADVERSARIAL NETWORKS (GANS)

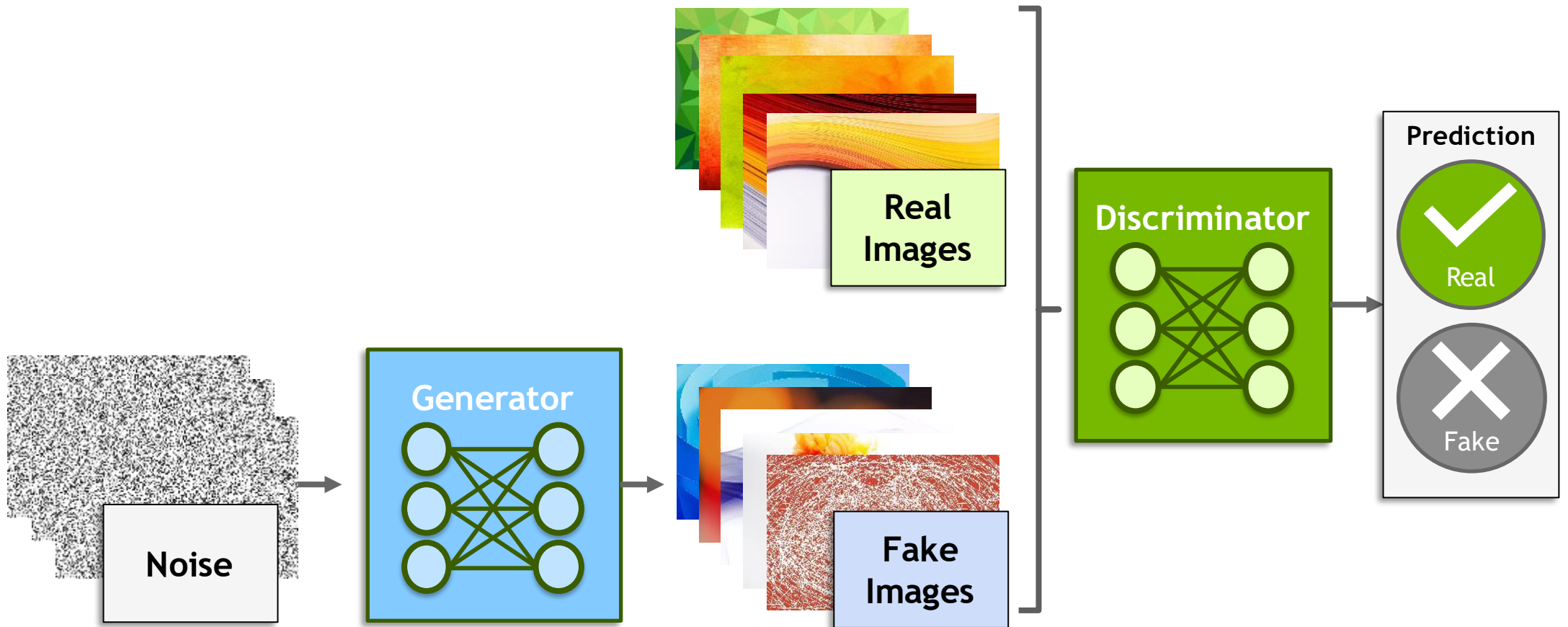

REINFORCEMENT LEARNING

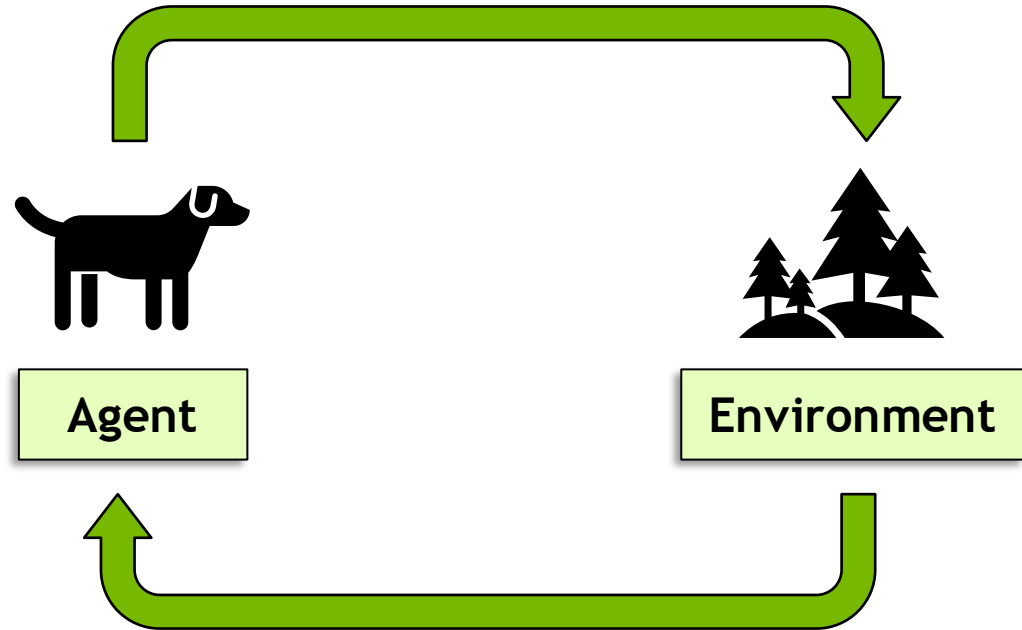



NEXT STEPS

ENABLING PORTABILITY WITH NGC CONTAINERS

Extensive

- Diverse range of workloads and industry specific use cases

Optimized

- DL containers updated monthly
- Packed with latest features and superior performance

Secure & Reliable

- Scanned for vulnerabilities and crypto
- Tested on workstations, servers, & cloud instances

Scalable

- Supports multi-GPU & multi-node systems

Designed for Enterprise & HPC

- Supports Docker, Singularity & other runtimes

Run Anywhere

- Bare metal, VMs, Kubernetes
- x86, ARM, POWER
- Multi-cloud, on-prem, hybrid, edge

NGC Deep Learning Containers

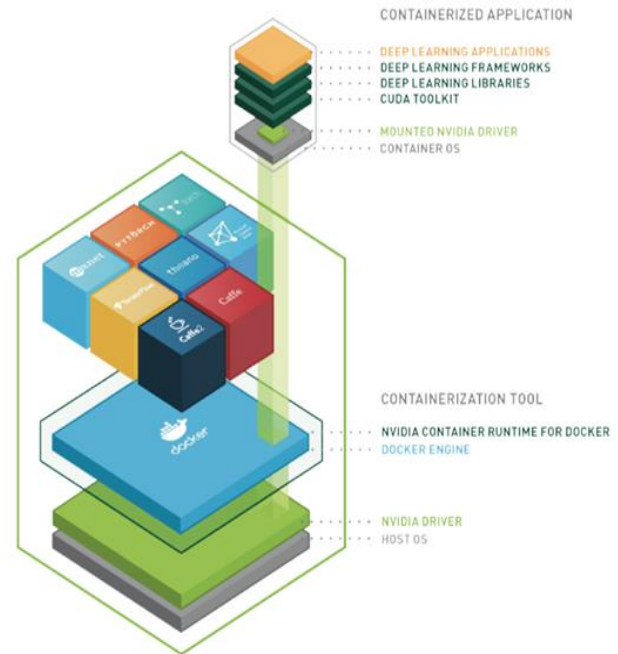

CONVERSATIONAL AI



JARVIS

HEALTHCARE



CLARA

SMART CITIES



DEEPSTREAM &
SMART PARKING

TELECOM



AERIAL

AUTONOMOUS DRIVING



DRIVE

ROBOTICS



ISAAC

HPC



HPC SDK

[Learn more about NGC Containers](#)

NEXT STEPS FOR THIS CLASS

Catalog: Containers / Containers: nvidia:dli-dl-fundamentals

DLI Deep Learning Fundamentals Course - ...

Publisher	Built By	Latest Tag	Modified	Size
NVIDIA	NVIDIA	v0.0.1	October 27, 2020	4.19 GB

Multinode Support
No

Multi-Arch Support
✕

Description
Base environment used in the NVIDIA Deep Learning Institute (DLI) Course Fundamentals of Deep Learning, along with Next Steps project.

Labels

Computer Vision DLI Jupyter Machine Learning Machine Learning & AI

Pull Command

```
docker pull nvcr.io/nvidia/dli-dl-fundamentals:v0.0.1
```

Step 1 Setup Docker

<https://www.docker.com/>

Step 2 Visit NGC Catalog

<https://ngc.nvidia.com/catalog/containers/nvidia:dli-dl-fundamentals>

Step 3 Pull and Run Container

Visit localhost:8888 to check out a JupyterLab environment with a Next Steps Project



CLOSING THOUGHTS

COPYING ROCKET SCIENCE





LET'S GET STARTED!

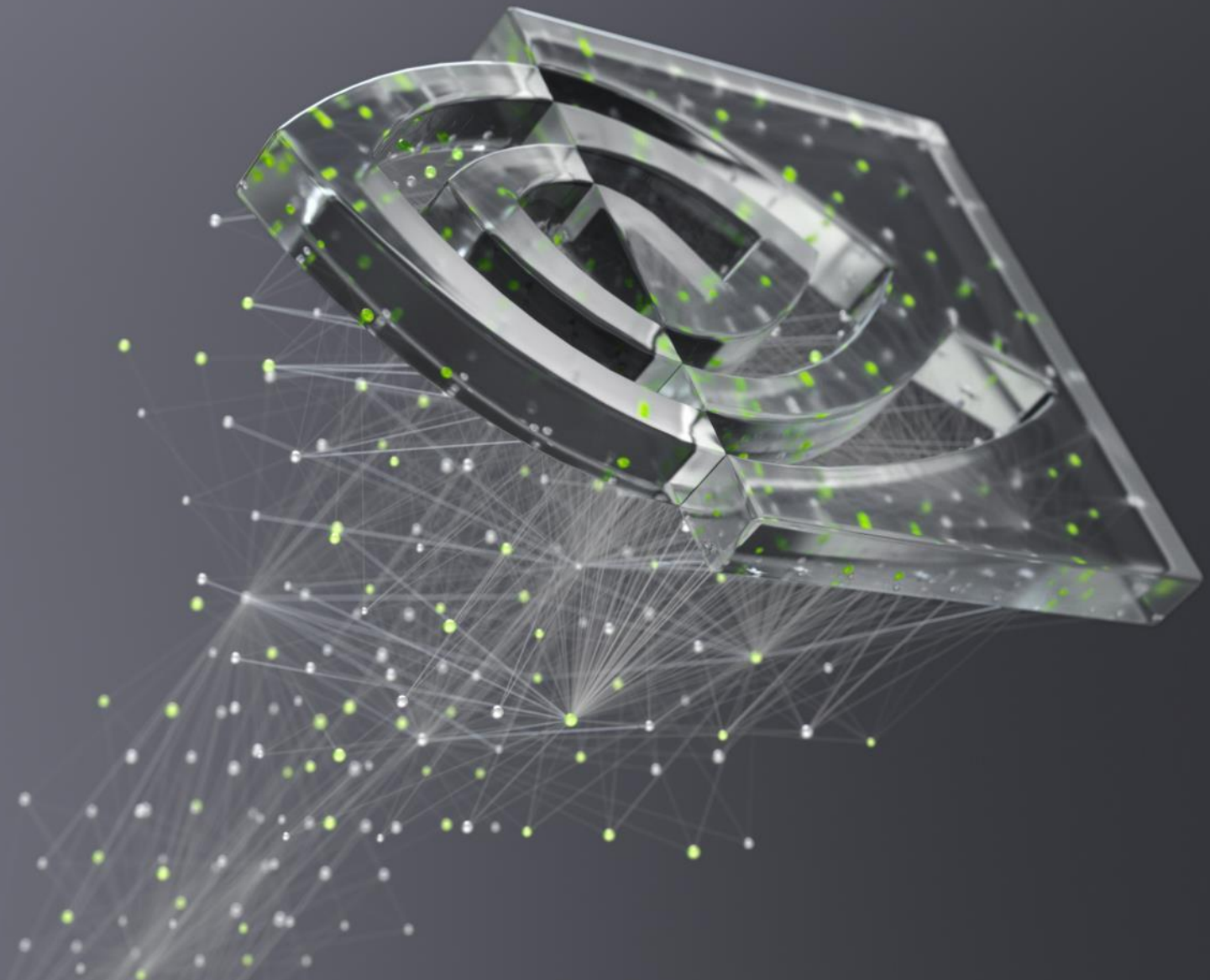

DEEP
LEARNING
INSTITUTE